



CEYLON PETROLEUM CORPORATION

BIDDING DOCUMENT

FOR

**REPAIRING OF TANK NOS. 30, 38 & 39 AT UPPER TANK FARM
CHINABAY, TRINCOMALEE**

B/42/2026

**CEYLON PETROLEUM CORPORATION
NO:609, DR. DANISTER DE SILVA MAWATHA,
COLOMBO 09**

The Standard Bidding Document that is applicable for this Contract is the Standard Bidding Document for Procurement of Works for Major Contracts with the CIDA Publication No. CIDA/SBD/02, Second Editions (January 2007) published by the Construction Industry Development Authority [CIDA], “Savsiripaya”, 123, Wijerama Mawatha, Colombo 07.

This Publication will not be issued with the Bidding Document and Bidder is advised to Purchase it from ICTAD/CIDA.

VOLUME 1

- Section 1; Instructions to Bidders
- Section 3; Conditions of Contract
- Section 5; Standard Forms (Contract)

VOLUME 2

Invitation for Bids

- Section 2; Bidding Data
- Section 4; Contract Data
- Section 6; Specifications
- Section 7; Form of Bid
- Section 8; Bills of Quantities
- Section 9; Schedules
- Section 10; Drawings
- Section 11; Standard Forms (Bid)

VOLUME 1

Section 1 INSTRUCTIONS FOR BIDDERS

Instructions to Bidders shall be read in conjunction with Bidding Data under Section 2 (Volume 2). Matters governing the performance of the Contractor, payments under the Contract, or matters affecting the risks, rights, and obligations of the parties under the Contract are included under Section 3 – Conditions of Contract (Volume 1) and Contract Data under Section 4 (Volume 2). However, a few such information is reproduced in this section to facilitate the bidders to price their bids.

Instructions to Bidders will not be a part of the Contract and will cease to have effect once the Contract is signed.

Section 3 CONDITIONS OF CONTRACT

Conditions of Contract shall be read in conjunction with the Section 4 – Contract Data in Volume 2, which shall take precedence over the Conditions of Contract

Section 5 STANDARD FORMS (CONTRACT)

Forms included in the Standard Bidding Document shall be used under this sections when submitting

- *Letter of Acceptance*
- *Agreement*
- *Performance Security*
- *Advance Payment Security*
- *Retention Money Guarantee*

VOLUME 2

Invitation for Bids (IFB)

Ceylon Petroleum Corporation

Ministry of Energy

**REPAIRING OF TANK NOS. 30, 38 & 39 AT UPPER TANK FARM CHINABAY,
TRINCOMALEE
(B/42/2026)**

1. The Chairman of the Department Procurement Committee on behalf of the Ceylon Petroleum Corporation (CPC) now invites sealed bids from eligible and qualified bidders for **REPAIRING OF TANK NOS. 30, 38 & 39 AT UPPER TANK FARM CHINABAY, TRINCOMALEE** as described below and estimated to cost of Rs.330,000,000.00 exclusive of Taxes.

These riveted steel storage tanks were constructed by the British during the 1920 – 1930 period using 25 – 10mm shell plate-to-plate riveting technology without using any fusion welding. Each tank has a total volume of 12,500 m³ with an approximate diameter and height of 35.3m x 16m. Since these tanks were not used for a prolonged period, it is required to carry out comprehensive repair work which includes but not limited to (i) bottom plate repair/rivets welding/lap joint welding (ii) blasting and painting external and internal (iv) repairing of ladders, handrails. (v) Hydro testing & Soak testing (vii) installation of fire water rings & foam systems pipe support, tank gauging systems (viii) Construction of fire pump house. *etc.* The construction period is 180 days.

2. Bidding will be conducted through the National Competitive Bidding Procedure.
3. To be eligible for contract award, the successful bidder shall not have been blacklisted and shall meet the following requirements.

Specialty	Grade	Party
Heavy Steel Fabrication	EM1	Bidder or Partner in Charge of Joint Venture (JV)
Building Construction	C4 or above	Bidder or Partner in Charge of Joint Venture (JV)

4. Qualifications requirements to qualify for contract award include:
 - 4.1 The Bidder/Any member of the Joint Venture shall have successfully completed at least one (01) contract as a main contractor for construction or repair of steel storage tanks of similar nature and complexity, with a minimum value of not less than Rs.100 Million, in accordance with API Standard 650/653 (latest edition), within the last five (05) years.
 - 4.2 The minimum amount of liquid assets and/or credit facilities, net of other contractual commitments and exclusive of any advance payments, shall not be less than Rs.65 Million. For the purpose of evaluation, financial capacity shall be assessed based on the financial statements for the last three (03) years. In the event that the Bidder's financial capacity during the year 2021, or 2022 was adversely affected due to the COVID-19 pandemic, the Bidder may substitute such year(s) with preceding years (up to 2016), subject to submission of acceptable justification and supporting documentary evidence.
5. Interested bidders may obtain further information from the Manager (Procurement & Stores) of Ceylon Petroleum Corporation, No. 609, Dr. Danister De Silva Mw, Colombo 09, procuregeneral@ceypetco.gov.lk and inspect the bidding documents at the address given below from 30.06.2026 until 21.07.2026 from 0900hrs. to 1500hrs.

6. A complete set of Bidding Documents in English language may be purchased by interested bidders on the submission of a written application to the address given below from 22.07.2026 until 21.07.2026 from 0900hrs to 1500hrs. upon payment of a non-refundable fee of Rs. 50,000.00. (Rs. 41,339.40 + 2.5% SSCL + 18% VAT). The method of payment will be measured & pay/ Lump Sum basis.
7. Bids shall be delivered in duplicate to the address given below **on or before 1400 hrs. on 22.07.2026.** Late bids will be rejected. Bids will be opened soon after closing in the presence of the bidders' representatives who choose to attend.
8. Bids shall be valid up to 17.11.2026.
9. All bids shall be accompanied by a Bid Security of Rs.4 million Bid Security shall be valid up to 15.12.2026.
10. A mandatory pre-bid meeting and site visit will be held at 1000hrs. on 10.07.2026 at Trincomalee Upper Tank Farm
(Google map location: <https://maps.app.goo.gl/fN6GG4yFPekub8VZ7>)

The address(es) referred to above is(are):

Chairman,
Department Procurement Committee,
C/o Manager (Procurement & Stores),
Ceylon Petroleum Corporation,
No. 609, Dr. Danister De Silva Mawatha,
Colombo 09.
Tele: 011 - 7296336
Fax: 011 - 2106769

E-mail : procuregeneral@ceypetco.gov.lk

SECTION - 2

BIDDING DATA

This section shall be read in conjunction with Section 1 – Instructions to Bidders and is intended to provide specific information in relation to corresponding clauses in Section 1. Whenever there is a discrepancy, the provisions in Section 2 – Bidding Data shall supersede those provided in the Section 1 – Instructions to Bidders.

BIDDING DATA**Clause Reference Instructions to Bidders****1.1 Employer's Name and Address:**

Name: Ceylon Petroleum Corporation

Address: No. 609, Dr. Danister De Silva Mawatha, Colombo 09, Sri Lanka.

1.1 Scope of Works

The work comprises the comprehensive repair and refurbishment of Tank Nos. 30, 38 & 39 including, but not limited to the following.

- (i) Repair of bottom plates, roof plates including rivet welding, lap joint welding and associated steel repairs.
- (ii) Fabrication and welding of cover plates over riveted and lap joint areas.
- (iii) Surface preparation by abrasive blasting and application of protecting coating systems for both internal and external surfaces.
- (iv) Repair and/or fabrication of ladders, handrails, platforms and other attachments.
- (v) Fabrication & installation of support brackets and fixtures for fire water ring mains, foam systems and tank gauging systems
- (vi) Fabrication and installation of nozzles for product pipelines, drain lines, foam lines, vents and associated piping, including installation of valves and fittings.
- (vii) Hydrostatic testing of tanks and carrying out required non-destructive testing (NDT) in accordance with applicable standards.
- (viii) Construction of the Fire Hydrant Pump House with all associated civil, structural, and architectural works.

All works shall be carried out in accordance with relevant API standards (API 650/653), applicable international standards, and CPC specifications, ensuring structural integrity, operational safety, and long-term serviceability of the tanks.

Located at: Upper Tank Farm in China Bay – Trincomalee.

1.2 Time for Completion

The Time for Completion for the whole of works shall be 180 Calendar days from date of Purchase order issue.

2.1 Source of funds

The source of funds is Ceylon Petroleum Corporation

4.1 Qualification Information

The following information shall be provided in Section 9- Schedules:

- ICTAD/CIDA Registration
 - Registration Number:*
 - Grade:*
 - Specialty:*
 - Expiry Date:*
- VAT registration number:
- Legal status of the Bidder (i.e. Sole proprietorship, Partnership, Company, Joint Venture etc.) with supporting documents.
- Construction program in Gantt chart, Resource Histogram for the proposed works.
- Organization chart for the project.
- Authorization of signatory (Power of Attorney or equivalent)
- Total Monetary Value of Construction Work performed for each of the last three (03) years supported by audited financial statements. In the event that the Bidder demonstrates that the turnover for any of the years 2020, 2021, or 2022 was adversely affected due to the COVID-19 pandemic, the Bidder may substitute such year(s) with preceding years (up to 2016) to complete the five (05) year requirement, subject to submission of acceptable justification and supporting documentary evidence.
- List of construction equipment; proposed for the repair works
- Work plan and Method Statement for execution of the entire repair works
- Proof of Liquid Assets and/or Credit Facilities
- List of Manpower proposed for the repair works including key personnel such as Site Manager, Site Engineer, QA/QC staff, supervisors, welders, fitters & helpers etc,
- Curriculum Vitae (CVs) of Key Technical Staff proposed to be deployed for this repair works.

4.1 (c) No Modification Required**4.2 (a) ICTAD/CIDA registration required**

The registration required;

Specialty - Heavy Steel Fabrication.

Grade - EM1.

&

Specialty - Building Construction.

Grade - C4 or above

4.2 (b) Average annual volume of construction work performed in last 5 years

Average annual volume of construction work performed in last 5 years shall be at least **Rs. 350,000,000.00** In the case of a Joint Venture or partnership, this requirement may be satisfied by the combined average annual volumes of

construction work performed by all parties to the Joint Venture/partnership.

4.2 (d) Essential equipment

Proposal for the timely acquisition (own, lease, hire, etc.) of the following minimum required essential equipment shall be entered in Schedules.

	Type	Capacity
1.	Air Compressors	300-450CFM
2.	Airless Paint Machines	60:1, 3000psi
3.	MIG welding machines	350-500A
4.	ARC welding machines	250-400A
5.	Water pumps	
6.	All required civil construction equipment	
7.	All required Electrical equipment	
8.	NDT testing equipment	
9.	All required testing and monitoring instruments for painting.	

4.2 (e) Qualifications and experience of the Project Team

Shall comply the requirement in Section 6, Specification 6.4.10, 6.4.11 and 6.4.12.

4.2 (f) Liquid assets and /or credit facilities required

The minimum amount of liquid assets and/or credit facilities net of other contractual commitments and exclusive of any advance payments which may be made under the contract until the date of Project Completion shall be not less than Sri Lanka Rupees 50 million.

5.1 (a) ITB Clause 5.1(a) ICTAD/SBD/02 shall be read as follows;

Bid shall include all the information listed in clause 4.1 for at least one of the Joint venture partners.

5.2 ITB Clause 5.1(a) ICTAD/SBD/02 shall be read as follows;

One of the partners may have the qualification requirements for ITB 4.2 (a). The qualification for each of the partners of a joint venture shall be added together to determine the Bidder's compliance with the minimum qualifying criteria of ITB Sub-Clause 4.2(b) 4.2 (c) 4.2 (d) 4.2 (e) and 4.2 (f). However, for a joint venture to qualify, each of its partners must meet at least 25 percent of minimum criteria of ITB Sub-Clauses 4.2(b), 4.2 (f) and the lead partner must satisfy at least 40 percent of those minimum criteria. Failure to comply with this requirement will result in rejection of the joint venture's Bid. Subcontractors' experience and resources will not be taken into account in determining the Bidder's compliance with the qualifying criteria.

10.1 Clarification of Bidding Documents

Employer's address for clarification of bidding document is:

Officer : Manager (Procurement & Stores)
 Address : Procurement & Stores Function,
 Ceylon Petroleum Corporation

No. 609, Dr. Danister De Silva Mawatha,
Colombo 09

Telephone : 011 -7296336

Email : procuregeneral@ceypetco.gov.lk

13.1 (A) Bidders who fail to submit following document will be rejected without further evaluations, consider as Non-Responsive bids.

- (a) Duly filled and signed Form of Bid (in the format indicated Section 7)
- (b) Bid Security
- (c) Power of Attorney for the signatory to the Bid
- (d) Section 2 – Bidding Data
- (e) Section 4 – Contract Data
- (f) Section 6 – Specification
- (g) Section 8 – Priced Bills of Quantities
- (h) Section 9 – Duly filled Schedules

13.1 (A) (j) Documents comprising the Bid

- (a) Qualifications and experience of managerial and technical staff stated in 6.410, 6.411 & 6.4.12 in Specification including curriculum vitae and
- (b) Copy of the valid certificate of Registration (PCA 3) issued by the Registrar of Companies.

13.1 (B) (d) Additional information is; Qualifications and experience of managerial and technical staff stated in 6.410, 6.411 & 6.4.12 in Specification including curriculum vitae.

14.4 Adjustments for change in cost

The Contract is not subjected to price adjustment

15.1 Currency of Bid

The Bid shall be quoted in Sri Lankan Rupees (LKR) only.

16.1 Period of Bid validity:

The Bid shall be valid for 119 days (**up to 17.11.2026**). A Bid valid for a shorter period will be rejected as non-responsive.

17.1 The amount of Bid Security

The Amount of Bid Security is Sri Lankan Rupees Four Millions (LKR.4,000,000.00)

- 17.2 Validity of Bid Security**
The Bid Security shall be valid for up to 147 days (up to 15.12.2026) from the date of closing of the bid. Security shall be irrevocable and unconditionally en-cashable upon the first written request from the Procuring Entity issued by a licensed commercial bank operating in Sri Lanka approved by Central Bank of Sri Lanka.
- 19.1 Pre-Bid meeting**
A pre –bid meeting will be held on **10.07.2026 at 10:00 hours at the** Project Office, Ceylon Petroleum Corporation, Upper Tank Farm, China Bay, Trincomalee.
(Google map location: <https://maps.app.goo.gl/tYiYTNc2VGFYTpoy9>)
- 19.5** Nonattendance at the pre-bid meeting will be a cause for disqualification of the bidder
- 21.2 (a) Employer's Address for Bid submission**
Employer's address for the purpose of bid submission is the Office of the
**Manager,
Procurement and Stores,
Ceylon Petroleum Corporation,
01st Floor,
No. 609, Dr. Danister De Silva Mwt.,
Colombo 09.**
- 21.2 (b) Identification number of Contract**
Identification Numbers of the Contract: B/42/2026
- 22.1 Deadline for submission of Bids**
Bids should be submitted before 14.00 hours of Sri Lanka time on: **22.07.2026**
- 25.1. Bid opening**
Venue: **Manager,
Procurement and Stores,
Ceylon Petroleum Corporation,
01st Floor,
No. 609, Dr. Danister De Silva Mwt.,
Colombo 09.**
Soon after the deadline for submission of bids.
- 30.1** The employer will evaluate and compare only the bids determined to be substantially responsive in accordance with clause 28 of Instruction to Bidders. Criteria and maximum point system for the evaluation of Technical Proposal is as follows;

No	Evaluation Criteria	Max Points
1	Similar type reverted tank repair experience in last 5 years	
	Tank volume $\geq 10,000 \text{ m}^3$	20
	Tank volume $< 10,000 \text{ m}^3$	5
2	Welded Tank construction/repair in last 5 years	5
	Tank volume $\geq 10,000 \text{ m}^3$	5
	Tank volume $< 10,000 \text{ m}^3$	3
3	History of project values within last 3 years	15
	10-100 million LKR (2.5points per each project)	5
	More than 100 million LKR (5points per each project)	10
4	Complete list of construction equipment which will be at site of construction	5
5	Tank bottom repair methodology (maximum 20 points)	20
	Poor	0-5
	Satisfactory	6-10
	Good	11-15
	Very Good - Technology adoption	16-20
6	Project Scheduled / Gantt chart	5
7	Resource histogram	5
8	Organization chart for the project	3
9	Quality assurance and quality control plan for the project (Includes WPS, ITPs, NDT procedures) provided	3
10	Availability of qualified level II NDT technicians for the construction site.	3
11	Availability of qualified sufficient numbers of site staff.	3
12	Availability of qualified sufficient numbers of qualified Welders for the construction site.	3
13	Availability of sufficient numbers of laborers for the site as per the provided resource histogram.	3
14	International Certifications of the firm (ISO 9001, ISO 45001, OHSAS 18001, ISO 14001)	2
	Total	100

The minimum Technical Score (St) required to pass is 60 points.

- ❖ The bids that scored pass mark from the Technical Evaluation will be subjected to the Financial Evaluation.
- ❖ The lowest evaluated Financial Proposal (F_m) will be given the maximum financial score (S_f) of 100 points. The financial scores (S_f) of the other Financial Proposals will be computed according to the following formula,
- ❖ $S_f = 100 \times (F_m / F)$ in which “S_f” is the financial score of the relevant responsive bid and “F” is the price of the proposal under consideration.
- ❖ Proposals will be ranked according to their combined technical (S_t) and financial (S_f) scores using the weights (T = the weight given to the Technical Proposals while P = The weight given to the Financial Proposals)
- ❖ T = 0.4 and P = 0.6 where T + P = 1

- ❖ Total Score , $S = (S_t \times T) + (S_f \times P)$
- ❖ The firm who scored the highest total, S, (combined technical and financial score) will be selected as the successful bidder for the contract.

31.1 For Domestic Bidders

- (a) For an **individual/sole proprietorship** the bidder shall be a Sri Lankan;
- (b) For an **individual firm** -
 - (i) such firms shall be registered in Sri Lanka;
 - (ii) should not sub contract more than ten percent (10%) of the contract price, excluding provisional sums to foreign contractors.
- (c) The application of the margin of preference for a **joint venture of domestic firms**:
 - (i) Would be limited only to joint ventures of individual firms who meet the criteria stipulated in (b) (i) & (ii) above;
 - (ii) Joint venture agreement or JV company registration should be submitted with the performance bond.

Domestic Bidders shall submit the documentary proof for above requirements under Schedule -1 “General Information”.

35.1 Amount of Performance Security

Performance Security acceptable to the Employer given in the Form for Performance Security given in the bidding document shall be a Guarantee obtained from;

- a commercial bank operating in Sri Lanka approved by Central Bank of Sri Lanka,
- a bank based in another country but the guarantee “confirmed” by a bank in Sri Lanka approved by Central Bank of Sri Lanka,

The amount of Performance Security is **5 %** of the Initial Contract Prices.

The Performance Security shall be valid until 28 days beyond the expected completion date of Defects Liability Period.

37. Adjudicator

The Adjudicator proposed by Employer is **Construction Industry Development Authority (CIDA)/ former ICTAD**.

Fees and types of reimbursable expenses to be paid to the Adjudicator shall be on a case to case basis and shall be shared by the Contractor and the Employer. (50% by the Employer and 50% by the Contractor)

SECTION - 3

CONDITIONS OF CONTRACT

Conditions of Contract shall be read in conjunction with the Section 4 – Contract Data in Volume 2, which shall take precedence over the Conditions of Contract.

SECTION - 4

CONTRACT DATA

This section shall be read in conjunction with Section 3 – Condition of Contract, and is intended to provide specific information in relation to corresponding clauses in Section 3. Whenever there is a discrepancy, the provisions in Section 4 – Contact Data shall supersede those provided in the Section 3 - Condition of Contract.

CONTRACT DATA

Clause Number/s	Conditions of Contract	
1.1.2.2 & 1.3	<p>Employer’s Name and Address</p> <p>Ceylon Petroleum Corporation, 609, Dr. Danister De Silva Mawatha, Colombo 09</p>	
4.2	<p>Contractor's Name & Address:</p> <p>Name:</p> <p>Address:.....</p> <p>.....</p>	
1.1.2.4 & 1.3	<p>Engineer's name & Address</p> <p>Name: Mechanical Engineer</p> <p>Address: Ceylon Petroleum Corporation, 609, Dr. Danister De Silva Mawatha, Colombo 09 Sri Lanka.</p>	
1.1.3.3	Time for Completion of the Works	Time for completion of the whole works shall be 180 Calendar days from date of Purchase order issue.
1.1.3.7	Defects Notification Period	Defects Notification Period is Three Hundred and Sixty Five (365) Days
2.1	Right of access to the Site:	14 days after the Letter of Acceptance
3.1	Engineer’s Duties and Authority	The Engineer shall obtain the specific approval of the Employer before taking action under the following Sub-Clauses of these conditions: (a) Clause 13 - COC, where the final effect of the variations increase the Contract Price
4.2.1	Amount of Performance Security	The amount of Performance Security is 5% of the Initial Contract Price. The Performance Security shall be valid until 28days beyond the expected completion date of Defects Liability Period. The acceptable form is Unconditional Guarantee

4.8 Safety Procedures

All persons engaged in work at Ceylon Petroleum Corporation, Trincomalee Tank Farm shall be acquainted with the following regulations and their consent to abide by them shall be an essential condition of their permit to work at the tank farm.

- ❖ The whole of the premises within the boundary fence is constituted a danger area with the exception of any area expressly exempted by the CPC Project Director (hereinafter called the Director).
- ❖ Before work of any nature is commenced in any area by the Contractor, his employees, agents or invitees, the Contractor must obtain the Director's authorized signatories necessary for excavation permits, safety certificates and clearance certificates and if the work involves sparks of flames, also a fire permit.
- ❖ The Contractor, his employees, agents or invitees must observe all precautions stipulated in these documents. If the work cannot be completed in the period for which these documents are valid, the work shall be discontinued until the documents are renewed.
- ❖ Persons under 18 years of age should not be employed by any contractor or by any sub-contractor for carrying out any contract work in any part of the tank farm.
- ❖ It is a condition of the permit to work at the tank farm that all persons engaged at the tank farm shall submit to be searched by the tank farm's Security Officials. This search may take place, either at the time of entry to the tank farm or at any other place and during any time while the employees are in the tank farm, at the discretion of the Senior Security Officer, Tank farm.
- ❖ Smoking is strictly prohibited in any part of the Site.
- ❖ The contractor shall observe the speed limit of 30kmph for vehicles and 24kmph for motorcycles within the Tank Farm premises and all vehicles must be mechanically sound and have an efficient exhaust, silencer, horn, brake, filler cap and tyre of good condition. All contract drivers must possess a valid driving license.
- ❖ The vehicles used by the contractor should only be driven on the recognized main roads in the Tank Farm and no vehicle should leave a main road to the Tank 30, 38 & 39 and enter into any other area without having a valid permit.
- ❖ Mobile cranes and other lifting equipment used for the contract job must be load tested and test reports must be produced to the CPC HSE Department.

- ❖ If any contract work involves scaffolding, it should be erected as per Factories Ordinance No. 45 of 1942-Section 40 and CIDA (ICTAD) Safety Guidelines.
- ❖ The Contractor shall ensure that his employees and those of any of his sub-contractors shall not make use of any equipment, material or property of any kind whatsoever belonging to the Corporation unless the written permission of the corporation has been obtained beforehand.
- ❖ The Contractor shall ensure that so far as is compatible with the work being carried out, the area in which his workers and /or agents are working shall be kept free of all equipment, material or property of any other kind which may constitute an accident hazard. If it is necessary in the opinion of the Contractor for such equipment, material or property to be on site, it will be the Contractor's responsibility to ensure all necessary safety precautions are observed by his own employees and those of his sub-contractors.
- ❖ The contractor must supply all personal protective equipment necessary for the contract employees to carry out the contract work. All contract employees should follow Safety Regulations and ensure to wear personal protective equipment.
- ❖ All accidents caused to the contractor's employees must be reported to CPC HSE Department immediately.
- ❖ After completion of the contract work by the contractor the area involved with the contract work should be inspected by the CPC HSE Department to ensure that the cleanliness and good housekeeping practices had been followed. The area involved with the contract work should be certified by the CPC HSE Department before the final payment is made.
- ❖ If the Contractor / Sub Contractor intend to use electronic equipment / radioactive equipment the contractor shall inform the engineer in charge and give the complete details of such equipment and the purpose for which such equipment is used and obtain the permission from the CPC HSE Department before commencing the contract work.
- ❖ Any employee, agent or invitee of a Contractor consciously or without consciousness, breaking the above Rules shall be liable to have his permit to work at the site terminated immediately.
- ❖ In addition to the above it will be contractor's responsibility to abide by the relevant clauses of Factories Ordinance of Sri Lanka in respect of all work carried out at the site and the safety of personnel engaged and equipment used at site.

- ❖ Contractor shall pay special attention to the following clauses of the Factories Ordinance of Sri Lanka. However, the responsibility of the contractor will not be limited to the clauses listed below but will cover all other conditions in the whole Factories Ordinance and its amendments.
 - Clause 27 - Hoists and lifts
 - Clause 28 - Chains, Ropes & Lifting Tackle
 - Clause 29 - Cranes and other Lifting Machines
 - Clause 30 - Construction and Maintenance of floors, passages and stairs.
- ❖ The mobile phones will not be allowed to bring Tank Farm premises without proper authorization / approval.

4.22 Security of the site

- ❖ Police clearance for personnel going to be engaged in this job will have to be obtained and produced to CPC security by the contractor.
- ❖ All contractors' personnel and their vehicles will be required to obtain gate passes before entering into the Tank Farm.

6.7 In addition a technical person with B.Sc. engineering degree or higher qualification in relevant discipline and qualified safety officer shall be available full time at site.

6.9 Bidder is requested to provide a complete schedule of manpower at various grades deployed at site during execution of the project. All welders to be qualified as per ASME Sec. IX in presence of CPC Mechanical Engineer at CPC site. Welding of any type will not be allowed without proper qualification of welders by CPC. Pipe welders shall be qualified for all pipe joints as per ASME Sec. IX.

7.2 All local fabrication and installation at site will be inspected by CPC Mechanical Engineer with concurrence of the contractor's own inspection. In the event of any rejection arising out of quality of standard of fabrication/installation according to API Standard 650/653 (latest edition), such items shall be replaced by the contractor at no cost to CPC. In view of standard of fabrication that have to be maintained throughout the construction, CPC reserves the right to reject services of workers whose skills do not meet the skills required.

The contractor is required to follow QA/QC procedures with documentations relevant to every fabrication in maintaining every aspect of quality assurance and controlling. Every fabrication is required acceptance or rejection sheets with provisions for signatures and comments of inspectors of CPC and the contractor. This documentations as a QA/QC brochure have to be submitted to CPC before the final payment.

CPC Engineers will carry out inspection at all stages of construction.

8.7	Liquidated damages for the Works	0.05 % of the Initial Contract Price per day
8.7	Maximum amount of liquidated damages	10% of the Initial Contract Price
12.2 (b)	Method of Measurement	Sri Lanka Standard 573: 1999 UDC 69(08374)
13.4(b)	Percentage for Adjustment of Provisional Sums	Not applicable
13.7	Adjustments for Changes in Cost	Not applicable
14.2	Total Advance Payment	20 % of the Initial Contract Price excluding Provisional Sums & Contingencies. The advance payment will be paid after submitting the advance payment security issued by a commercial bank operating in Sri Lanka approved by Central Bank of Sri Lanka. The advance payment shall be recovered by deducting 25% of each bill submitted for payment. The guarantee shall remain effective until the advance payment has been repaid.
14.2	Number of timing of installments	One instalment
14.3(c)	Percentage of Retention	10% of certified value of works (Applicable for all interim payments except final interim payment)
14.3(c)	Limit of Retention	5% of the Initial Contract Price (Applicable only for Final interim payment)
14.5	Minimum amount of interim payment	LKR 25 million
14.8	Alternative method for Payment of Retention	Not applicable.
18.2	Third Party Insurance (Including Employer's Property)	Insurance cover to the amount of LKR 100Million for the entire period of construction work. The contractor shall take special measures to safeguard the adjacent storage tanks and allied facilities at the site.
18.3	Insurance for Contractor's Personnel	A copy of insurance policy for the workmen of the contractor as per the Workmen Compensation Act shall be forwarded to CPC prior to commencement of the work.

SECTION - 5

STANDARD FORMS (CONTRACT)

- **FORM OF LETTER OF ACCEPTANCE**
- **FORM OF AGREEMENT**
- **FORM OF PERFORMANCE SECURITY**
- **FORM OF ADVANCE PAYMENT SECURITY**

Notes on Standard Forms (Contract):

Bidders should not complete the Form of Agreement at the time of preparing of bids. The successful Bidder will be required to sign the Form of Agreement, after the award of contract. Any corrections or modifications to the accepted bid resulting from arithmetic corrections, acceptable deviations, or quantity variations in accordance with the requirements of the bidding documents should be incorporated into the Agreement.

The Form of Performance Security, Form of Advance Payment Security and Form of Retention Money Guarantee should not be completed by the Bidders at the time of preparation of bids. The successful Bidder will be required to provide these securities in compliance with the requirements herein or as acceptable to the Employer.

SECTION - 6
SPECIFICATIONS

SPECIFICATIONS

6.1 Scope of supply by CPC

6.1.1 Construction material

Supply of,

- (a) Steel plates for repair/reconstruction of the tank bottom, roof, and drip ring, deflection plate, toe guard, side plates for stair way & insert plates for inlet, outlet, manholes & drains except checkered plates.
- (b) Pipes & flanges for fabricating nozzles such as inlet, outlet & drains, etc,
- (c) Paint, thinner except for cleaning purposes.

6.2 Construction utilities.

- 6.2.1 The Contractor may arrange to take water from the sources at the Tank Farm premises for construction requirements, sanitary and other requirements of the staff & labor. Since the CPC cannot commit to the sufficiency of the water available at the site, the Contractor shall make necessary arrangements to source fresh water for hydro-testing.
- 6.2.2 The Contractor shall arrange necessary power supply for construction and other purposes at their own cost. However, the Contractor at his discretion may use the power supply of 400V AC, 4 wire (TPN), 50 Hz with Max load of 60A if arranged by the CPC through CEB during the contract period. If so, the cost of electricity consumption will be deducted from the total contract value. Further, the Contractor shall make necessary arrangements at its own cost to get the power supply from the CEB metering point within the Tank Farm premises to the work site.
- 6.2.3 The maximum load that the CPC can feed will be 60A, 3 phases.
- 6.2.4 CPC will reserve the right to disconnect the power supply to the contractor without prior notice, if any of the foresaid conditions are violated.

6.3 Site fabrication facilities

- 6.3.1 CPC will provide sufficient space in tank farm premises for establishment of a site shop for fabrication. The bidder shall indicate the extent of area needed for the site shop. The contractor shall under no circumstance use this site facility for any other purpose not involved with the job.

6.4 Scope of supply by contractor

6.4.1 Supply of material;

- (a) Heavy Duty GI Pipes from 1 1/4" Dia. and fittings for the installation of hand rails of shell stairs.
- (b) Heavy Duty GI Pipes from 1 1/2" Dia. and fittings for the installation of guard rails of the tank roof.
- (c) Brackets for fire water rings of the roof, foam pipelines & instrument cables & deflection plates.
- (d) Brackets, Nuts and bolts for the installation of the handrail and deflection plate.
- (e) 6mm Thick mild steel checkered plates for the shell stairs/platforms.
- (f) 2" x 2" (1/4" Thick) Angle irons for the shell stairs/platforms and toe guard.
- (g) 3mm, Stainless Steel cable, Calibrated strips and other installation material required for repairing existing gauge system of the tanks.(Approximate length of cable - 17m)

- (h) Installation material required for manholes and lid hangers.
- (i) 3"x3" Angle irons for insulation panel brackets.
- (j) 2" x 2" (1/4" Thick) Angle irons for the pipe supports for 2" heat coil pipes.
- (k) Necessary pipes/hoses/pumps/gaskets to fill the tanks for the hydro test.

6.4.2 Supply of consumables;

Supply of all consumables such as welding electrodes, gas for cutting, grinding & cutting discs, abrasive materials for blasting, radiographic films, dye-Penetrant, chemicals for MPI and all other consumables necessary for the proper execution of the job.

6.4.3 Supply of temporary erection materials;

Such as scaffolding pipes, planks, reinforcement, wedges & etc.

6.4.4 Supply of all construction equipment;

Such as Welding machines, Grinders, Air Compressors, Cranes & other rigging equipment, Vacuum testing, Ultrasonic thickness gauging & scanning, Radiographic equipment, Painting equipment (*such as spray paint equipment and hand tools, brushes, rollers, blasting machines*), Holiday testing & Paint thickness gauges, illuminating lamps, jacks, ventilating blowers and other tools required for proper execution of the job.

Note:

1. All equipment should be maintained in good working order and tested where applicable and conform to requirements of the Latest Factories Ordinance of Sri Lanka.
2. If in any case the electricity supply at site will not be made available by CPC or the supply is found insufficient, the Contractor shall arrange a generator supply at their own cost.

6.4.5 Diesel and lube oil;

For welding generators & electricity generators (if any), air compressors (If any), cranes and other mechanical equipment required for repair of the tank shall be supplied by the contractor.

6.4.6 Supply of all manpower;

Needed including supervision to carry out the work described under "Contractor's scope of Work" in clause 6.4.10, 6.4.11, 6.4.12, 6.4.13.

6.4.7 Simultaneous Work Execution;

To minimize the total project duration, the Contractor is required to carry out repair, blasting, painting works on Tank Nos. 30, 38, and 39 simultaneously. The Contractor shall mobilize adequate resources, including but not limited to, separate sets of air compressors, sandblasting pots, welding machines, airless spray units, and distinct skilled labor crews for each tank. A detailed resource-loaded Master Program of Works showing concurrent activity paths for all three tanks must be submitted for CPC.

6.4.8 An insurance cover for site equipment so that CPC will be released from any responsibility regarding accidents, losses etc.

6.4.9 An insurance cover for all manpower at site as per the Workmen Compensation Act.

- 6.4.10 The contractor shall supply all required Non-Destructive Testing (NDT) equipment, consumables and NDT technicians with minimum 05 years' experience to perform necessary NDT to fulfill requirement of API 650/653 and ASME section V.
- 6.4.11 The contractor shall employ level II qualified (*from a recognized institution acceptable to CPC such as ASNT / ISO & PCA*) personal with minimum 05 years' experience for all NDT work on fulltime basis at site and at least one level III qualified UT scanning personal with minimum 05 years' experience on intermittent basis (when & where required). CVs and copies of certification along with originals of such personal shall be submitted to CPC for review and approval before commencing work.
- 6.4.12 The contractor shall deploy a certified welding supervisor with AWS SCWI or CSWIP 3.1 with minimum 05 years' experience on fulltime basis at site when the welding works are in progress and the welding procedure shall be provided by the welding supervisor for the approval of CPC prior to welding commence.
- 6.4.13 CPC reserves the right to terminate the service of the NDT personnel if the quality of their service deemed to be unsatisfactory.
- 6.4.14 The electrical power distribution board shall be provided with suitable protection devices such as Earth leakage circuit breakers, miniature circuit breakers, isolators, etc.
- 6.4.15 All cables used for power distribution above 48V shall be of armored type.
- 6.4.16 All portable electrical appliances used inside the tank shall be at low voltage, 110V and should be fed through a center earthed transformer.
- 6.4.17 Power distribution inside the tank should comply with IEE wiring regulations for construction sites.
- 6.4.18 For welding procedures & welder qualifications see clause No.6.13.3 & 6.13.4

6.5 Contractor's scope of work

The scope of work of the contractor is defined in general and shall include the following, but not limited to the same. The bidder shall also carry out all the related work that are not listed in this document, but required for completion of the entire work as specified in this Bidding Document.

The summary of the main scope items is given below; however, the bidder remains responsible for completing all necessary works to achieve full project completion.

6.5.1 General

- The Contractor shall provide a comprehensive written warranty for a period of **five (05) years** from the date of the Final Completion Certificate. This warranty shall cover the entire scope of work, including but not limited to:
 - Leakage: Any product leakage from seal-welded riveted joints, rivet heads, or new 32" manhole installations.
 - Structural Integrity: Any damage or failure of the newly installed steel components, brackets, or toe guards.
 - Surface Protection: Any premature coating failure, including blistering, peeling, or corrosion under insulation (CUI) resulting from improper surface preparation or application.

The Contractor shall, at their own expense, mobilize and rectify any such defects within 14 days of notification by CPC.

- All the under-mentioned repair jobs/items in Section A of the Schedule of Prices shall be carried out on a lump sum fixed price basis. If CPC requests any additional works, the rates quoted in Section B of the Schedule of Prices shall prevail.
- The contractor shall transport all required material to Trincomalee Upper Tank Farm as necessary and also materials removed after the repair, shall be transported back to the location inside the Tank Farm given by CPC Engineers and stack them properly. Site cleaning and completion of tank repair in all respect and make ready for commissioning to the satisfaction of CPC.
- These tanks have been designed and constructed by British during 1920-1930. All mechanical Repair work, tolerances and testing have to be performed as per API 650/653 (latest edition) and the final acceptance will be made by CPC.
- Contractor shall submit Inspection Test Plan (ITP) for the approval of CPC prior to commencement of the tank repair works.
- Contractor shall carry out all non-destructive testing such as UT Scanning, Radiography, Dye penetrant, vacuum testing & Paint thickness gauging etc. as specified in the ITP and wherever required as directed by CPC using contractor's own equipment & manpower at its own cost in the presence of CPC's inspectors and submit reports for CPC's approval.
- Provision of access to tank shell (internal and external), foam and fire water, roof and roof truss by erection of fix type or movable scaffolding as per the CIDA/STD/04 & provision of platforms at required levels & locations using load tested wooden planks or load tested plates for the repairing works. Scaffolding plates/planks should be securely clamped or tie up to their supports.
- Erection of safety barrier/ water jacket around the tank where necessary to protect the surrounding tanks and environment from construction sparks and hot projective and to avoid pollution from blasting works. Maintenance of safety barrier/water jacket is the total responsibility of the contractor until remove it.

6.5.2 Bottom repair

- Dismantle and remove roof plates safely from an edge (if necessary) to facilitate steel plates required for the tank bottom repair/replacement with roof attachments, topmost platform & accessories. Repair (if necessary) all special fittings such as gauge hatch, foam fittings, brackets, flanges, and firewater fittings as instructed by CPC.
- Dismantle and remove the existing floating suction pipe arm and attachments inside the tanks and transport it to a location specified by CPC.
- Carry out patch repairs (if necessary) of Bottom Plates as identified by CPC based on the UT spot survey (Drawing ref: CPC_Tk30_Bottom_T, Drawing ref: CPC_Tk38_Bottom_T & Drawing ref: CPC_Tk39_Bottom_T). In addition, Contractor shall perform a UT scanning of the bottom plates using tank bottom scanner and carryout patch repairs or weld fillings as instructed by CPC.
- All the rivets and riveted lapping joints shall be seal welded (using fillet welding) as per the welding sequence determined by the Contractor's welding supervisor approved by CPC.
- The estimated aggregate linear length of the riveted lap joints on the 8mm bottom plate is approx. 1100m. per one tank. The bidder shall quote a lump sum price

under item number 5.2 of the BOQ to achieve complete sealing by a suitable welding technique. Additional welding requirements as decided by the CPC based on in situ inspections will be paid at a rate quoted under item No. 05 of SECTION B of the BOQ.

- The estimated aggregate linear length for Seal welding the rivet heads is approx. 2100m per one tank. The bidder shall achieve the complete sealing of rivet heads using a suitable welding technique.
(Approximate 18,000 number of rivets with the rivet head diameter of 1 ½ ”)
- Plate bending & welding of 8mm thick and 1’ wide corrugated cover plates over all riveted lap joints and adjacent rivet lines having provisions for pressure testing of the entire or segment wise in a single operation.
(Approximate length of covering plate 850m per tank)
- Welding of 8mm thick and 1 ½’ wide cover plates over annular ring, having provisions for pressure testing of the entire or segment wise in a single operation.
(Approximate length of covering plate 120m per tank)
- Low thickness areas on the annular plates shall be weld build up as instructed by CPC and the payment will be paid as per the rates stated in Section B of Schedule of Prices.
- Patch plate welding to close the existing 04 drain nozzles on the bottom as instructed by CPC.
- Patch plate welding to blank the 05 flanged holes on the bottom as instructed by CPC.
- After the repairing all the sealed welds, welds shall be tested and verified by Dye Penetrate and re-repair if necessary.
- After the repairing all the cover plate welds, welds shall be tested and verified by Dye Penetrate and pressure testing and re-repair if necessary.
- Material supply, fabrication and welding of 2”x2” “L” iron supports on the bottom for the 2” heating coil pipes. (Pipe support approx:1000nos)

6.5.3 Shell repair

- Modify the existing 10” nozzle by removing the existing flange and installing new flange accordance with API 650 and the CPC-approved drawings.
- Install 01nos new 16” NPS welded nozzle designed as per accordance with API 650 and the CPC-approved drawings.
- Install 04nos of new 4” NPS drain pipes at the bottom of the shell in accordance with API 650 and the CPC-approved drawings.
- Install 03nos of 8” NPS nozzles to install foam system in accordance with API 650 and the CPC-approved drawings.
- Install 06nos of 2” NPS nozzles to install heating coil in accordance with API 650 and the CPC-approved drawings.
- Removal of existing manholes and installation of 03nos new 33” diameter flanged-type manholes with covers and lid hangers, utilizing provided steel plates in accordance with the specified in API650-Section 5.7 Shell Openings and API 653.

(Plate cutting and rolling must be done by the contractor)

- Fabrication and welding of blank plates for 1nos of existing manholes.
- Material supply & install Brackets to fix the foam lines, Fire Water lines & instrument cables as instructed by CPC and the design shall be approved by CPC.
- Supply, fabrication, and welding of 3"x3"x5mm L-angle iron support brackets at 1.2m vertical intervals on the tank shell for the installation of glass wool insulation panels, in accordance with CPC instructions and approved designs.
- Repair the internal monkey ladder.
- Material supply and replace the missing segments of the tank shell stairway and repair the corroded or mechanically damaged areas.
- All the welds on the tank shell shall be tested and verified by Dye Penetrate & re-repair if necessary.
- Install a Drip gutter ring at the bottom of the shell as per the Drawing ref: CPC_Tk30_38_39_005.
- Material supply & repair the existing manual tank gauging system and calibrate.
- Bituminous layer shall be applied to the shell bottom external and the foundation ring as directed by CPC to avoid leaks.
- Installation of four lugs near the existing drain pits to connect the anodes.

6.5.4 Roof Repair

- Patch repairing of roof plates (where necessary) on the roof structure and fillet weld as per the drawings provided by CPC and Dye Penetrate testing of welds as per API Standard 650/653 (latest edition).
- Supply and installation of L-angle brackets and installation of 2mm thick steel toe guards for the tank roof perimeter and stairways, including all necessary nuts and bolts, design shall be approved by CPC.
- Fabrication, repair and installation of roof attachments & accessories such as roof manholes with covers, inspection doors, PV valve outlets, float well for level indicator, gauge hatch, radial hand rail, circumferential hand rail, Toe guard, cooling water drencher system, for fire water deflection plates (as necessary).
- Material supply and fabrication and modification of existing goose neck outlet using flange neck as instructed by CPC and the design shall be approved by CPC.
- Install Brackets to fix the foam lines, Fire Water lines & instrument cables as instructed by CPC and the design shall be approved by CPC.

6.5.5 Heating coil installation

- Fabrication and welding of 2" SCH80 pipes and fittings for the heating coil as per the Drawing ref: CPC_TTF_HC_001 (Approx. pipe laying – 2000m, Welding joint- 900 per one tank)
- All butt welds (100%) shall be tested and verified by radiography test by level II qualified RT inspector.

6.5.6 Painting

➤ Internal

- Cleaning of the tank bottom if there is any slug or other derbies which cannot be removed by the blast cleaning.
- Blast cleaning & painting of tank bottom internal & first shell course (from bottom) as per the paint specification – A. (except lap joints of the shell and annular L angle)
- Blast cleaning & painting of 300mm wide strip along riveted lap joints of the shell internal and the annular L angle as per the specification - E.

➤ External

- Blast cleaning & painting of roof plates external as per the paint specification – D
- Blast cleaning & painting of all welding joints on roof plates externally after welding at site as per the paint specification of – A & D
- Blast cleaning & painting or Scrape, wire brush & paint tank shell external, stairways, foam & fire water line brackets, hand rails, plat forms & all attachments as per the paint specification – B & C
- Roof external side final finish coat shall be applied after completion of all repair works as per paint specification D.
- CPC Logo & Tank Number shall be painted on the Roof top and Tank shell as per CPC requirement.(Logo diameter 16m)

➤ Standard Working Procedure for painting

- Steelwork preparation



To provide a surface which will ensure optimum coating performance, preparation is required to remove surfaces which have a sharp edge. These include, but are not limited to, plate edges, weld spatter, plate laminations, weld undercuts, or gas cut surfaces.

- Surface preparation

Oil or grease, salts, dirt, chalk marks and similar contaminants shall be removed as far as possible, prior to surface preparation, using an appropriate method in accordance with ISO 12944-4. (This procedure must be followed after every coat of paint)

- Sharp Edges, weld spatter, cavities and deformations are to be removed in accordance with ISO 8501-3, table-3
 - Assess the steel surface for Rust grades as per ISO 8501-1
 - Surface shall be cleaned by abrasive blast cleaning (ISO 12944-4 Cl.6.2.3.1.2) in accordance with ISO 8504-2 (Cl. 5.1.2)
 - Surface cleanliness shall be as per Sa2.5 in accordance with ISO 8501-1 (External surface of tank)
 - Surface profile shall be 50- 75microns as per ISO 8503-4.
 - Surface salts concentration (e.g. chloride deposits) shall be less than 5 microgram/cm² prior to painting.
- Compressed Air

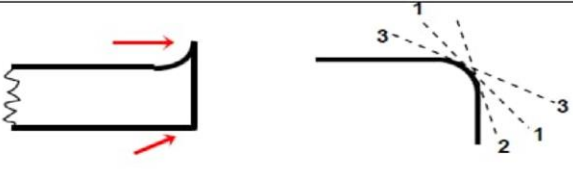
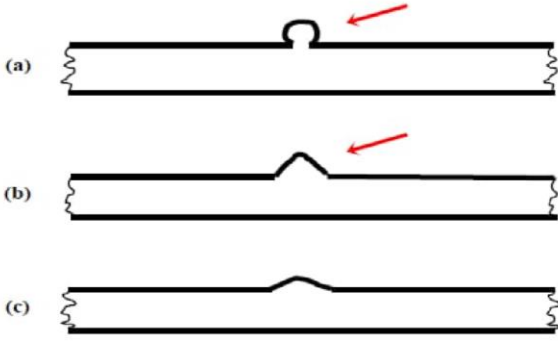
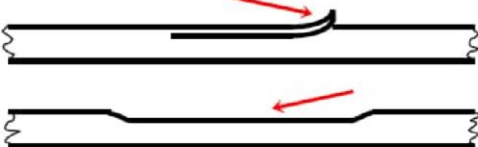
- Air used for blasting must be clean, oil free and dry. Moisture and Oil separators have to be used to ensure the same.
- The pressure should be at least 7kg per cm² (100lbs per inch²) at the nozzle.
- Abrasive
 - Abrasive used for blasting should be dry and free from dirt, oil, grease or contamination and have content of water soluble matter not exceeding 0.05%.
 - The abrasive must be capable of producing the standard of cleanliness and surface profile specified. (Sa2.5 and profile of 50- 75 microns except sigma 650)
 - Abrasives like copper slag should not be recycled more than once, and should not be contaminated with soil
- Cleaning
 - Before initial blast inspection, the bulk of the spent abrasive should be removed. Any substandard areas should be identified and repaired. All marking paint, chalk etc., must be removed after rectification.
 - Fabrication repair (if any) should be carried out before application of the primer.

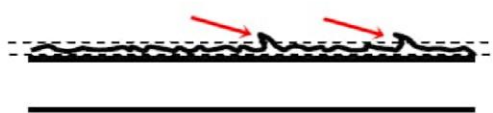
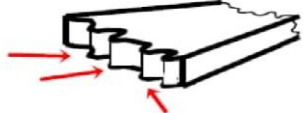
ITEM	PROBLEM/SOLUTION
Sharp Edge	<p>Remove sharp edges or gas cutting edges with grinder or disc sander to achieve a radius of 1.5mm-2.0mm</p> 
Weld Spatter	<p>Remove spatter observed before blasting by grinder, chipping hammer etc.</p> <p>For spatter observed after blasting: Remove with chipping hammer /scraper etc. Where spatter is sharp, use disc sander or grinder until obtuse Obtuse spatter – no treatment required</p> 
Plate Lamination	<p>Any lamination to be removed by grinder or disc sander</p> 
Undercut	<p>Where undercut is to a depth exceeding 1mm and a width smaller than the depth, repair by welding or grinding may be necessary</p> 
Manual Weld	<p>For welding bead with surface irregularity or with excessive sharp edges, remove by disc sander or grinder</p> 
Gas Cut Surface	<p>For surfaces of excessive irregularity, remove by disc sander or grinder</p> 

Following inspection of the blast profile and standard, remaining traces of abrasive and dust should be removed from all areas.

➤ General Site Requirements

(a) Weather Conditions

- Surfaces to be coated must have a temperature at least 3°C (5°F) above the dew point, immediately following blasting and priming, intermediate and topcoat application, and must also remain in this condition during curing of the coatings.
- As a guide, relative humidity levels of 25-80% give optimum painting conditions, although some applications may be carried out up to 85% relative humidity.
- Painting can be carried out on steel temperature up to 45 C.
- Painting should not be carried out during windy conditions.

(b) Cleanliness

Any contaminants which may come in contact with the steel (even before surface preparation comments) can compromise the performance protective coating system, and as such all effort must be made to keep the working area clean. It is good working practice to establish a clean area where painting is being done. Cleanliness must be maintained throughout all stages of the application.

(c) Paint Storage Facility

All paints should be stored ideally between 10°C (50°F) and 30°C (86°F) and facilities may be needed to store the materials in the correct temperature range prior to mixing and application.

➤ STRIPE COATING

- Stripe coating is an essential part of good working practice, and stripe coats are highlighted in the detailed product specification sheets.
- Stripe coats are applied to areas where it is difficult to get the required coverage, including but not limited to:
 - Plate edges
 - Welds
 - Difficult access areas
- Stripe coats are normally applied to a specified film thickness range via a combination of narrow angle airless spray and brush methods. Over coating intervals for the stripe coats should be strictly adhered to as per the individual product data sheet.
- The following diagram indicates key areas requiring stripe coats'

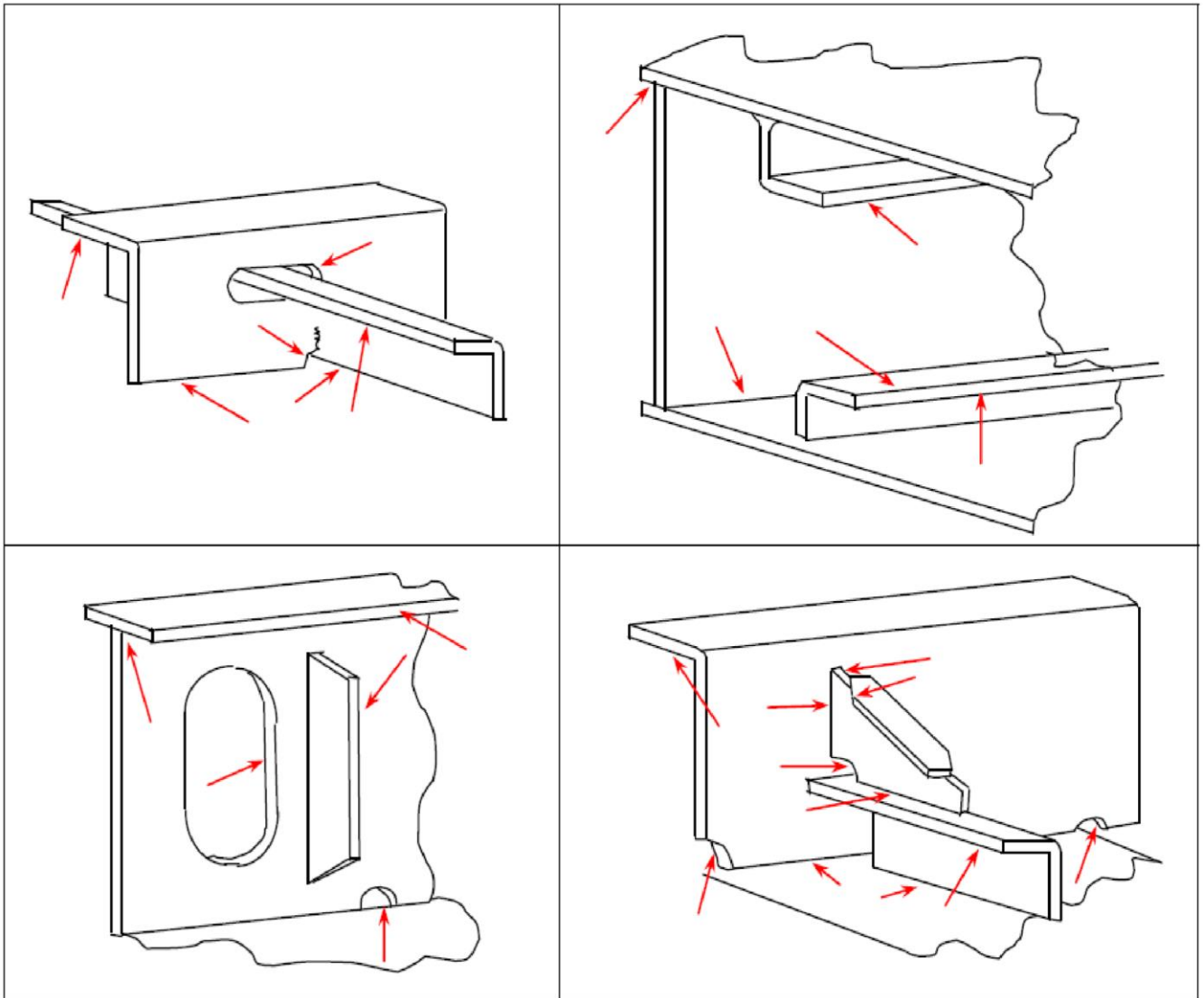

➤ INSPECTION

- The coating should be inspected using a suitable non-destructive magnetic gauge to verify the average total applied system thickness. The material should be free of pinholes and other defects.
- Completed repaired areas shall be visually inspected and shall be free of runs, sags, bubbles and solvent entrapment.
- Surrounding adjacent areas to the localized repair shall be inspected visually for any accidental damages due to surface preparation method for repairs such as “over sanding” or mechanical damages.
- Maintain inspection report where Product name, Batch number, Application detail of each layer, ambient conditions (at each occasion of surface cleaning or coating application) including ambient temperature, surface temperature, dew point and relative humidity.

➤ Repair procedure

1. Repairs of minor areas when the primer paint is affected

- The area to be repaired must be fresh water washed and dry.
- Remove any corrosion by means of either prepare the surface according to SP11 using bristle blaster
- Proper feathering to be carried out in surrounding edges immediately to provide key for subsequent paint application.
- Apply, for Internal area of tank (For Major- Reinstall as per specification)

If small areas are involved and application is by brush, several coats may be required to achieve the correct dry film thickness. If the area is large then airless/air spray has to be employed. A full recoat would be required to maintain aesthetics.

2. Repairs when Primer is intact & the Intermediate Coat is damaged.

- The area to be repaired must be fresh water washed and dry.
- Remove any corrosion by means of either-prepare the surface according to SP 3
- Proper feathering to be carried out in surrounding edges immediately to provide key for subsequent paint application.

If small areas are involved and application is by brush, several coats may be required to achieve the correct dry film thickness. If the area is large, then airless/air spray has to be employed. A full recoat would be required to maintain aesthetics.

3. Repairs when Primer & Intermediate Coat is intact and Finish Coat is damaged.

- The area to be repaired must be fresh water washed and dry.
- Abrade area immediately surrounding repair to provide key for subsequent paint application.

If small areas are involved and application is by brush, several coats may be required to achieve the correct dry film thickness. If the area is large, then airless/air spray has to be employed. A full recoat would be required to maintain aesthetics.

6.5.7 Painting Specifications:

Painting Specification A :**Bottom and bottom shell course (internal side).**

	Paint	DFT Microns	Over coating Interval	
			Min	Max
First Code	International, Interline850 - Grey	100	5 - 8Hrs	21-30Days
Second Code	International, Interline850 - White	125	5 - 8Hrs	21-30Days
Third Code	International, Interline850 - Grey	125	5 - 8Hrs	21-30Days
Thinner	International GTA220 or equal			
Surface Preparation	Dry Abrasive Blast to ISO8501-1:2007(E) Sa-2.5 with RZ (Average Roughness Factor) specified by the Product Data Sheet			
Paint Application	Airless Spray			

Painting Specification B**Shell external side**

	Paint	DFT Microns	Over coating Interval	
			Min	Max
Primer	International, Intergard 269 - Red	50	4 - 8Hrs	
Intermediate	International, Interseal 670HS - Aluminum Grey	200	6 -18Hrs.	
Finish	International, Interthane 990– White	50	3 – 6 Hrs	
Thinner	International GTA220 and GTA713			
Surface Preparation	Dry Abrasive Blast to ISO8501-1:2007(E) Sa-2.5 with RZ (Average Roughness Factor) specified by the Product Data Sheet			
Paint Application	Airless Spray			

Painting Specification C**All platforms and hand railings, foam and fire water pipe lines**

	Paint	DFT Microns	Over coating Interval	
			Min	Max
Primer	Zink phosphate or equivalent	170	2 - 6 Hrs.	60-90 Days
Finish	Enamel paint compatible to primer	50	2 - 6 Hrs.	4 -7 Days
Thinner	Generic thinner			
Surface Preparation	Blast Cleaning to SA 2½			

Paint Application	Brush/roller/Airs pray/Airless ray
-------------------	------------------------------------

Painting Specification D**Roof (External side)**

	Paint	DFT Microns	Over coating Interval	
			Min	Max
Primer	International, Intergard 269 - Red	50	4 - 8Hrs	
Intermediate	International, Interseal 670HS – Aluminum Grey	200	6 -18Hrs.	
Finish	International, Interthane – White	50	3 – 6 Hrs	
Thinner	International GTA220 and GTA713 or equal			
Surface Preparation	Dry Abrasive Blast to ISO8501-1:2007(E) Sa-2.5 with RZ (Average Roughness Factor) specified by the Product Data Sheet			
Paint Application	Airless Spray			

Painting Specification E :**300mm wide stripe on bottom and shell lap joints (internal side).**

	Paint	DFT Microns	Over coating Interval	
			Min	Max
First Code	Sigma Guard 650 – White	Not specified	24Hrs	20Days
Second Code	Sigma Guard 650 – White	300	24Hrs	20Days
Third Code	Sigma Guard 650 – White	300	24Hrs	20Days
Surface Preparation	Dry abrasive should be within the acceptable purity & conductivity which doesn't exceed 75 μ S/cm and be able to generate angular blast profile (Rz) with 75 – 125 mics with Spd \geq 10.0/mm ² . It is preferred the Grit/Copper Slag or Steel Grit			
Paint Application	Brush / Airless Spray			

6.5.8 Hydro testing

- Closing of manholes and preparing for hydro test of the tank by make necessary connection via pipes / hoses / pumps from the water sources.
- Water filling will be undertaken by the Contractor.
- Once the tank is filled, water level up to the maximum liquid level, shall be held for a minimum of 24 hours and facilitate the CPC inspectors to witness as per the ITP.
- Measuring of tank foundation levels before water filling and after 100 % filling of water as instructed by CPC.

- If any leaks found, Contractor to rectify the defects and perform NDT test and repeat the hydro test again until there are no leaks found.
- Contractor to perform hydro test by utilizing the water from salt free source.

6.5.9 Tank calibration

- After completion of repairs tank, calibration shall be performed by a reputed third-party and reports to be submitted to CPC.

6.5.10 Construction of Fire Hydrant pump house

Complete execution of civil, structural, and architectural works required for the construction of a Fire Pump House in compliance with provided drawing, NFPA 20, local building codes, and project specifications but not limited to the following.

- Site preparation and earthworks including surveying and layout, excavate for, structural column footings, pump foundations, and trenches down to specified founding levels. Supply, place, and compact dry earth filling to 95% compaction density under the entire floor slab and pump foundations.
- Concreting column foundations, columns, plinth beams, pump plinths providing isolation joints for required places.
- Install a rubber coated GI mesh around the building perimeter providing the GI frame. Ensure the mesh is mechanically tensioned and anchored to the structural plinth beam using galvanized tension bars, bands, and heavy-duty fasteners to prevent sagging or wind rattle.
- Construct internal concrete cable trenches with steel cover plates, Internal and external drainage trenches.
- Fabricate and erect structural steel Universal Beams connected to concrete columns via MS tie plates and sag rods. Install Lip Channel purlins. Install 0.47mm thick Z-Roofing sheets (AZ 200 Type) along with matching Ridge Cap (AZ 200 Type) and valance boards.
- Supply and install Type D2 (3900 x 3000) Aluminum Roller Doors within dedicated framed bays for main equipment access. Also provide 2 personal access 1200mm x 2100mm doors with GI frames at the front and back of the GI mesh area.

6.6 Site conditions

- 6.6.1 The Bidder is responsible for its own investigations to establish sufficient and accurate information for the construction of proposed storage tank. The Bidder shall visit the proposed sites and shall ascertain the nature and location thereof and all conditions which may affect construction.
- 6.6.2 The Bidder shall make its own assessment of any and all of the information provided in this bidding document and collect own information. CPC is not responsible for the accuracy or completeness of any such information.

6.7 Design consideration

- (a) The Contractor shall verify the basic design provided in the attached general arrangement drawing and shall carry out comprehensive engineering calculations to

justify the sizing of all principal components.

- (b) All calculations shall be carried out in strict accordance with the latest edition of API Standard 650 and shall be submitted to the Engineer for review and approval prior to commencement of fabrication or construction.
- (c) Approval of the Contractor's design by the Employer or the Engineer shall not, under any circumstances, relieve the Contractor of full responsibility and liability for the adequacy, accuracy, safety, and performance of the design and construction works.
- (d) The submitted design shall include, at a minimum:
 - Thickness calculations for all primary components including reinforcements
 - Specification of materials and equipment in compliance with ASME/ASTM/API standards
 - Inspection and testing requirements
 - Nozzle orientation

6.8 General specifications

6.8.1 Quality Assurance and Control

- The Contractor shall provide a Quality assurance and Quality control plan at the time of bidding, both of which are subject to approval and acceptance by the CPC Inspection department. The QA & QC plan shall detail each activity to be carried out during the execution of the works. Each activity shall be supported by a detailed procedure for that activity. The QA & QC plan will also detail the inspection requirements of each specific activity, listing whether it be a witness or hold point, and defining the responsibilities of the various parties at these stages of the works.
- The Quality Control Plan (QCP) shall as a minimum have the following.
 - (a) Drawing Approval
 - (b) Material Identification
 - (c) Welding Procedure Approval
 - (d) Welders Certificate Approval
 - (e) Weld Map Approval
 - (f) Dimensional Checks Records
 - (g) NDE (RT, PT, MPT), Vacuum box test.
 - (h) Hydro test/ Pressure test
 - (i) Coating Inspection
- Prior to the start of fabrication, the contractor shall submit the QCP to the Engineer for review and approval. The Contractor shall ensure that all his sub-contractors have obtained a copy of this specification.
- Prior to the start of work welders must perform welding test on site and qualified for the job.
- The Contractor shall have the necessary equipment and staff knowledgeable in test procedures to carry out the quality control required to ensure compliance

with the specification.

- The Contractor shall accept full responsibility for the quality of his work and of materials used, irrespective of any quality surveillance that may be carried out by the Engineer or his representative.
- In the event of any rejection arising out of quality of standard of fabrication/installation according to API Standard 650/653 (latest edition), such items shall be replaced by the contractor at no cost to CPC. In view of standard of fabrication that have to be maintained, CPC reserves the right to reject services of workers not meeting up to skills required.
- The Contractor shall:
 - (a) Maintain Quality Control records in accordance with the Quality Plan during execution of the contract. Such records shall be available to the Engineer or his Representative at each Quality Surveillance visit.
 - (b) Mark or securely label each component with a unique identification tag, and
 - (c) Carry out such tests as are required to ensure compliance with the specification.
- The CPC Inspection Engineer will oversee the Contractor's Quality Assurance and Quality Control (QA/QC) program and will provide guidance to the Contractor's QA/QC personnel to ensure adherence to approved procedures and plans, thereby ensuring high-quality project deliverables.
- All Non-Destructive Examination (NDE) activities shall be conducted under the surveillance and/or witnessed by the CPC Inspector as per the approved QCP. NDT reports shall be submitted for approval of CPC and the results of such inspections, including acceptance or rejection, will be formally communicated to the Contractor. In the event of dispute, the Engineer's decision shall be final.
- For carrying out quality surveillance, the Engineer or his representative shall be granted access to any part of The Contractor's premises relevant to the work being carried out, at any reasonable time.
- No variation from specification, or change of materials to be used from those stated in the tender documents, will be permitted without the written approval of the Engineer. Products equivalent to those specified may be submitted for approval, but may not be substituted without the written approval of the Engineer. Adequate information shall be supplied by The Contractor to Engineer in order to assess the claim of equivalence from The Contractor.
- Notwithstanding any requirements or other information given, or submissions to The Engineer for approval, the contractor shall retain full responsibility for the design and construction of the tank and associated fittings and ensure these meet all requirements of API 650, API 653 considering the additional special requirements given herein.
- The cost of quality control shall be inclusive in The Contractor's tender price.

6.9 Health, Safety and Environmental (HSE) Requirements

The Contractor is requested to provide a sound-working environment to all employees involved in the construction, testing and commissioning. This includes the consideration of but not limited to:

- All applicable national and international laws, guidelines and standards
- All applicable national and international codes and standards with respect

to Occupational Health and Safety and Environmental Protection.

The Contractor shall be requested to submit a detailed HSE Plan considering the site configuration and the site conditions. The final HSE Plan must include the following content and objectives as a minimum:

1. Project policy statement
2. Roles and responsibilities
3. Site regulation, incl. E.g. Housekeeping, barricades, excavations, tools and equipment, electrical work, ladders and scaffolds etc.
4. Risk management & hazard identification
5. HSE training
6. HSE management of subcontractors
7. Work permit system
8. Personnel protective equipment
9. Inspection & auditing
10. HSE meetings
11. Incident investigation & reporting
12. Site security
13. Medical care & first aid.

The detailed HSE Plan shall demonstrate the Contractor's commitment to the highest standards of personal and general safety standards, health and occupational hygiene of the construction workforce during the project as well as the concept of an accident and injury free project.

The safety track record of the Contractor in previous projects should also be highlighted, as well as the methodology that it will adopt, particularly in the intense environmental conditions of the region, in order to ensure the highest standards of health & safety management on the construction site.

6.10 Material Properties

- i. Materials selected by the Bidder shall be proven adequate and sufficient for the complete term of the Project.
- ii. The Contractor shall carefully consider all corrosion and erosion possibilities subject to the environment of the Site and nearby facilities.
- iii. Where materials are specified in any part of the Employers Requirements, those materials are to be considered as minimum requirement.

6.11 Environmental Management Requirements

The Contractor shall avoid any environmental damage and/or concerns to the environment during any phase of the project.

The Contractor shall demonstrate during the construction, testing and commissioning that work is able to comply with all applicable environmental regulations and standards. Applicable standards for environmental protection must be fulfilled without any restrictions. This applies in particular but not limited to:

- i. Air emission limit values and standards
- ii. Air quality limit values
- iii. Limit values for environmental noise
- iv. Health and safety of construction workers and permanent staff.

6.12 Codes and Standards

The Bidder shall ensure that the engineering, design, construction, testing, etc. of, tank including all auxiliary facilities and systems, are according to Government and Local Authority Requirements, International Codes, Latest revisions of the following codes shall be governed.

Table 1

Document Title	Document Number
Standard for Welding Pipelines and Related Facilities	API 1104
Process Piping (Pressure piping)	ASME B 31.3
Specification for Line Pipe	API 5L
Specifications for Pipeline Valves	API 6D
ANSI – Pipe Flanges and Flanged Fittings	ANSI B 16.5
Large Diameter Steel Flanges	ASME B16.47
Welded Steel Tanks for Oil Storage	API STD 650
Tank Inspection, Repair, Alteration and Reconstruction Welded Steel Tanks for Oil Storage	API 653
API Specification for Oil Storage tanks with riveted shells	API Std 12A
Boiler and Pressure Vessel Code (Welding and Brazing Qualification)	ASME Sec IX
Boiler and Pressure Vessel Code (non-destructive examination-NDE)	ASME Sev V
Electrical Equipment for Explosive Gas Atmosphere (International Electro technical Commission) Part 10	IEC 60079

It is implied that the eligible Bidders are fully acquainted with the above Documents and therefore, those will not be issued to the Bidders with this Bidding Document. However, Bidders may purchase the same, if necessary, from CIDA, Savsiripaya”, 123, Wijerama

Mawatha, Colombo 7, Sri Lanka or other relevant organization.

In case of any conflict between the codes and standards, the following order of precedence shall govern: -

- i. Local laws (Sri Lankan Authorities)
- ii. CPC Specifications and Guidelines
- iii. International Codes and Standards

6.13 Technical specifications

6.13.1 Welding Procedure and Welder Qualification

The following welding electrodes shall be used for each category of joint.

- **ROOF**
All fillet welding joints on the roof – AWS E 7018 (or equivalent with prior approval of CPC)
- **SHELL & BOTTOM**
All lap joint fillet welding of bottom – AWS A5.20 (or equivalent with prior approval of CPC)
All rivet head fillet welding Joints & Butt-welding Joints – AWS E 7018 (or equivalent with prior approval of CPC)
- **PIPE BUTT JOINTS**
Root run – AWS E 6010 (or equivalent with prior approval of CPC)
Filling & capping – AWS E 7018 (or equivalent with prior approval of CPC)

The following welding procedures shall be used for above welding

- SMAW (Shielded Metal Arc Welding): Permitted for all positions; mandatory for tack welding and localized repairs. Low-hydrogen electrodes (e.g., E7018) shall be used for all shell-to-insert plate welds.
- GMAW (Gas Metal Arc Welding): Permitted for shop fabrication and controlled field environments. Not recommended for outdoor use.
- FCAW (Flux-Cored Arc Welding): Highly recommended for high-productivity welding on tank bottoms and long horizontal seams. Gas-shielded or self-shielded (FCAW-S) wires may be used.
- GTAW (Gas Tungsten Arc Welding): Permitted for root passes on nozzles and high-precision small-bore pipework.

6.13.2 Welding procedure specifications (WPS) for all types of joints to be submitted to CPC for approval and Welding Procedure Qualification test shall be carried out and test reports from a reputed third party shall be submitted to CPC.

6.13.3 All welders (except Pipe welders) to be qualified (4G/4F) as per ASME Sec. IX via a reputed institute for welder qualification acceptable to CPC. Welder Qualification certificates shall be submitted for CPC's approval before commencing the welding works. Welding in the tank will not be allowed without proper qualification of welders by CPC.

6.13.4 Pipe welders shall be qualified for all pipe joints (6G) as per ASME Sec. IX and bend test results by a third party to be submitted along with test pieces.

6.13.5 CPC reserves the right to terminate the service of the welders if the quality of their welding deemed to be unsatisfactory.

6.14 Technical documents and information

6.14.1 Documentation to be submitted after Award of Contract

The following describes the minimum scope of information, documents, drawings, etc. to be submitted by the Contractor to the Employer after award of contract during the site construction. The Employer reserves the right to request from the Contractor such additional information, drawings, documents, etc. as may be reasonably required for proper understanding and definition of the project.

Monthly progress reports shall be provided by no later than ten (10) days after the last day of each month.

Any revision of the project implementation schedule shall not be delivered later than fourteen (14) days after such revision.

6.14.2 Documentation to be submitted prior to Site Construction

All documents and permits required for site construction shall be submitted prior to site construction.

6.14.3 Documentation to be submitted during Site Construction

The following documents shall be submitted during site construction:

- i. CPC will coordinate all temporary building permits or the no-objection certificates, as applicable, issued by the various departments or other relevant Governmental Authority to the Contractor in accordance with applicable Law, and all related permits, consents and approvals related to the construction of Project.
- ii. The Contractor shall submit to the Engineer drawings, diagrams, graphs, curves, calculations, schedules for information, review or approval as described in the Contract. The quality of all documents submitted shall conform to acceptable international practice.
- iii. The Contractor shall provide the calibration certificates of all calibrated equipment to the CPC.
- iv. Biweekly progress brief reports - by no later than one (2) days after the last day of two-week including work progress. The minimum information shall be:
 - (a) Engineering activities
 - (b) Component and material purchase and receipt status
 - (c) Construction activities
 - (d) HSE
 - (e) Trainings executed
 - (f) Incidents
 - (g) Accidents
 - (h) Personal on site
 - (i) Number of staff
 - (j) Number of local staff
 - (k) 4-week look ahead schedule
 - (l) Recommendations for improvement
 - (m) Layout drawings which shall show the work status

6.14.4 Final Documentation

The Contractor shall deliver to the CPC the final documentation, both in digital and hard copies (2x). The final documentation shall comprise at least the following:

- i. The above-mentioned documents
- ii. All As-built drawings
- iii. Log sheets for painting work
- iv. Site safety procedures
- v. HSE procedure and plan
- vi. Key list and site access contacts
- vii. Components data sheets
- viii. Installation and O&M manuals from component manufacturers
- ix. Studies and tests (tests, geological / geotechnical analysis, static calculation wherever applicable)
- x. Mechanical completion documents including but not limited to:
 - a. Data sheets and manuals of all components and equipment
 - b. Calibration protocols
- xi. Warranties of component suppliers
 - a. Valves
 - b. Painting
- xii. Commissioning protocols

SECTION - 7

FORM OF BID

FORM OF BID

Name of Contract: **REPAIRING OF TANK NOS. 30, 38 & 39 AT UPPER TANK FARM CHINABAY, TRINCOMALEE.**

To: **Ceylon Petroleum Corporation,
No 609, Dr. Danister the Silva Mawatha, Colombo 09**

Gentlemen:

1. Having examined the Standard Bidding Document - Procurement of Works – Major Contracts [ICTAD/SBD/02 - Second Edition, January 2007], Specifications, Drawings and Bills of Quantities and Addenda for the execution of the above-named Works, we the undersigned, offer to execute and complete such Works and remedy any defect therein in conformity with the aforesaid Conditions of Contract, Specifications, Drawings, Bills of Quantities and addenda Nos.....for the sum of Sri Lankan Rupees.....
.....
(LKR) or such other sums as may be ascertained in accordance with the said Conditions.
2. We acknowledge that the Contract Data forms part of our Bid.
3. We undertake, if our Bid is accepted, to commence the Works as soon as is reasonably possible after the receipt of the Engineer’s notice to commence, and to complete the whole of the Works comprised in the Contract within the time stated in the Contract Data.
4. We agree to abide by this Bid until the date specified in ITB Clause 16,..... [*insert Date*] and it shall remain binding upon us and may be accepted at any time before that date.
5. Unless and until a formal Agreement is prepared and executed this Bid, together with your written acceptance thereof, shall constitute a binding Contract between us.*
6. We understand that you are not bound to accept the lowest or any bid you may receive.
7. We certify/confirm that we comply with the requirements as per ITB Clause 3 and 4 of the bidding documents.

Dated this day of.....20.....
Signature in the capacity of
duly authorized to sign bids for and on behalf of [*in block capitals or typed*]

Name :

Designation:

Address:

Witness:

*For a joint venture bid, add following to item 5.0: If this bid is a joint venture bid we undertake the responsibility to enter into a joint venture agreement among the joint venture partners. We are also well aware that in the event we fail to enter into a joint venture agreement the contract formed between us is null and void and our bid bond

will be forfeited by you.

SECTION - 8
BILL OF QUANTITIES

BILL OF QUANTITIES**CEYLON PETROLEUM CORPORATION****JOB : REPAIRING OF TANK NOS. 30, 38 & 39 AT UPPER TANK FARM CHINABAY, TRINCOMALEE****BID No: B/22/2026**

Section - A					
	Item	Qty (*)	Unit	Rate (Rs.)	Total (Rs.)
1	PRILIMINARY EXPENSES				
1.1	All the preliminary Expenses including but not limited to mobilization/demobilization, all insurances, bank charges, material transport & storage, sanitary facilities, welder qualification (as per 6.13.2, 6.13.3, 6.13.4) etc.	1	Lot		
1.2	Supply of Materials as specified in 6.4.1	3	Lot		
2	MISCELLANEOUS				
2.1	Supply of electrical power supply, power distribution board with suitable protection devices such as Earth leakage circuit breakers, miniature circuit breakers, isolators as specified in 6.2.2, 6.4.14, 6.4.15, 6.4.16, 6.4.17.	1	Lot		
2.2	Supply of Construction equipment & Diesel / lube oil as specified in 6.4.4 & 6.4.5	1	Lot		
3	GENERAL				
3.1	Supply of NDT equipment, consumables, technicians as specified in 6.4.10, 6.4.11, 6.4.12 & Perform NDT tests as specified in 6.5.1.	1	Lot		
4	ERECTION OF SCAFFOLDING & SAFETY BARRIER				
4.1	Erection of a safety barrier and scaffolding (external & internal) as specified in 6.5.1 using materials as specified in 6.4.3.	3	Lot		
5	BOTTOM REPAIR (6.5.2)				
5.1	Dismantle and removal of existing floating suction pipe arm and attachments	3	Lot		
5.2	Seal welding riveted lapping joints	3300	m		
5.3	Seal welding of the rivet heads	6300	m		
5.4	Cover plate welding over bottom lap joints	2550	m		

5.5	Cover plate welding over annular L angle and revert heads	360	m		
5.6	Patch plate welding to close the existing flange holes on the bottom	15	Nos.		
5.7	Patch plate welding to close the existing drain nozzles	12	Nos.		
5.9	Install sacrificial anodes connectors.	12	Nos.		
6	SHELL REPAIR - 6.5.3				
6.1	Modification of 10" existing nozzle	3	Nos.		
6.2	Install 16" NPS welded nozzle	3	Nos.		
6.3	Install new 4" NPS drain pipes at the bottom of the shell.	12	Nos.		
6.4	Install new 8" NPS nozzles to install foam system.	9	Nos.		
6.5	Install new 2" NPS nozzles to install heating coil.	18	Nos.		
6.6	Install new 32" manholes with lid hangers	9	Nos.		
6.7	Welding blank plate for existing manholes	3	Nos.		
6.8	Install brackets on the shell surface as specified	3	Lot		
6.9	Installation of L angle bracket rings for insulation work	3	Lot		
6.11	Repair the internal monkey ladder as specified	3	Nos.		
6.12	Repairing the tank shell stairways as specified	3	Nos.		
6.13	Install a Drip gutter ring at the shell bottom as specified	336	m		
6.14	Repair the existing manual tank gauging system	3	Nos.		
6.15	Apply a Bituminous layer at the shell bottom as specified in	336	m		
7	ROOF REPAIR - 6.5.4				
7.1	Patch plate repair as specified	1050	m		
7.2	Installation of toe guards	3	Lot		
7.3	Modification of existing goose neck	3	Nos.		
7.4	Fabrication, repair and installation of roof attachments as specified	3	Lot		
8	HEATING COIL INSTALLATION - 6.5.5				
8.1	Fabrication and welding of pipe supports for the coil	3	Lot		
8.2	Fabrication, welding and pipe laying	3	Lot		
9	PAINTING - 6.5.6				

9.1	Internal blast cleaning and painting as specified	4600	m ²		
9.2	External blast cleaning and painting as specified	7700	m ²		
10	WELDING TESTING				
10.1	Dye penetrant testing of all the welding carried out including revert head welds and lap joint welds patch plates welds.	3	Lot		
10.2	Leak testing of cover plate	3	Lot		
10.3	RT testing of all the butt joint welds (100%) of the heating coil	3	Lot		
10.4	Ultrasonic Scanning (UT) using tank bottom scanner	75	m ²		
11	HYDRO TESTING - 6.5.8				
11.1	Make necessary arrangement to source water	37500	m ³		
11.2	Perform Hydro test up to the satisfaction of CPC as specified	3	tanks		
11.3	Perform Hydro pressure test of the heating coil	3	tanks		
12	TANK CALIBRATION – 6.5.9				
12.1	Perform tank calibration and submission of reports	3	tanks		
13	CONSTRUCTION OF FIRE HYDRANT PUMP HOUSE-6.5.10				
13.1	Civil construction of the hydrant pump house	1	Lot		
	Contingency (10%)				
	Sub Total 1				
	SSCL (.....%)				
	Sub Total 2				
	VAT (18%)				
	Grand Total				

Section – B				
	Item	Qt	Unit	Rate (Rs.)
1	Erection of scaffolding and safety barrier -rate per 1m3	1	m ³	
2	Supply of generator power supply up to system commissioning (including sufficient diesel/lubricants)	1	per day	
3	Pad repair (8mm thickness) -rate per 1 m linear length (Bottom plates)	1	m	
4	Weld filling -rate per 1cm2 area	1	cm ²	
5	Liner fillet welding for 8mm thickness plate -rate per one pass per 1m length	1	m	
6	Painting			
6.1	<i>Internal - rate per 1m2 area (complete coats)</i>	1	m ²	
6.2	<i>External - rate per 1m2 area (complete coats)</i>	1	m ²	
7	NDT Testing			
7.1	<i>Dye Penetrate test (PT) - rate per 1m</i>	1	m	
7.2	<i>Ultrasonic Scanning (UT) - rate per 100cm2</i>	100	cm ²	
7.3	<i>Radio graphic testing (RT) – rate per 2” weld</i>	1	Nos	
7.4	<i>Radio graphic testing (RT) – rate per 16” weld</i>	1	Nos	

SUMMERY - BILL OF QUANTITIES

ITEM	DESCRIPTION	LKR AMOUNT / LKR
1	PRILIMINARY EXPENSES	
2	MISCELLANEOUS	
3	GENERAL	
4	ERECTION OF SCAFFOLDING & SAFETY BARRIER	
5	BOTTOM REPAIR	
6	SHELL REPAIR	
7	ROOF REPAIR	
8	HEATING COIL INSTALLATION	
9	PAINTING	
10	WELDING TESTING	
11	HYDRO TESTING	
12	TANK CALIBRATION	
13	CONSTRUCTION OF FIRE HYDRANT PUMP HOUSE	
	Sub Total I	
	Less discount if any	
	Sub Total II	
	SSCL	
	Total sum carried to form of bid	
	VAT (18%)	
	TOTAL AMOUNT WITH VAT	

Total amount in words (LKR):-.....
.....

VAT Amount :-

VAT registration no :-.....

Name of Bidder :-.....

Address :-.....
.....

.....
Date

.....
Signature & Common Seal
of the Bidder

Witness :.....
Name :.....
Address :.....
N.I.C. No:.....

Witness :.....
Name :.....
Address :.....
N.I.C. No:.....

SECTION - 9

SCHEDULES

SCHEDULES

Schedule 1 – General Information			
<p>(i) If pre-qualification is done the bidders are required to include information subsequent to that submitted with the pre-qualification application.</p> <p>(ii) For joint ventures, each joint venture partner shall furnish information separately.</p>			
ITB Clause reference	Description	Information (to be filled by the bidder)	Remarks
	ICTAD Registration		Provide certified copies and label as attachment to clause 3.1
	Registration Number		
	Grade		
	Specialty		
	Expiry Date		
	Legal Status		Provide certified copies of Registration
	Written Power of attorney of the signatory to the Bid	Provide original or certified copy of the power of attorney attested by a Notary and label as attachment to clause 4.1(a)	
	If a Joint Venture, names and addresses of Joint Venture Partner	1. 2. 3.	Provide a draft copy of the Joint Venture Agreement or alternatively the memorandum of understanding
	If a Joint Venture, Name of Lead Partner		
	For joint ventures, each joint venture partner shall furnish Legal Status separately		
	(Lead Partner)		Provide certified copies and label as attachment to clause 4.1(a)
	Legal Status		
	Place of registration		
	Principal place of business		
	Written Power of attorney of the signatory to the Bid	Provide original or certified copy of the power of attorney attested by a Notary and label as attachment to clause 4.1(a)	

Schedule 1– General Information continued

.....

	If a Joint Venture, names and addresses of Joint Venture Partner	1. 2. 3.	Provide a draft copy of the Joint Venture Agreement or alternatively the memorandum of understanding
	If a Joint Venture, Name of Lead Partner		
For joint ventures, each joint venture partner shall furnish Legal Status separately			
	(Partner 2)		Provide certified copies and label as attachment to clause 4.1(a)
	Legal Status		
	Place of registration		
	Principal place of business		
	Written Power of attorney of the signatory to the Bid	Provide original or certified copy of the power of attorney attested by a Notary and label as attachment to clause 4.1(a)	
	VAT Registration Number		
	Name (Partner 3)		Provide certified copies and label as attachment to clause 4.1(a)
	Legal Status		
	Place of registration		
	Principal place of business		
	Written Power of attorney of the signatory to the Bid	Provide original or certified copy of the power of attorney attested by a Notary and label as attachment to clause 4.1(a)	
	VAT Registration Number		

Schedule 2 – Annual Turn-over Information

- (i) If pre-qualification is done the bidders are required to include information subsequent to that submitted with the pre-qualification application.
- (ii) For joint ventures, each joint venture partner shall furnish information separately.

Year	Turn-over	Remarks
2021 / 2022		Attach audited reports and label as attachment to clause 4.2
2022 / 2023		
2023 / 2024		
2024 / 2025		
Average		

Schedule 3 – Adequacy of Working Capital

If pre-qualification is done the bidders are required to include information subsequent to that submitted with the pre-qualification application.

Source of credit line	Amount	Remarks
		Provide documentary evidence and label as attachment to clause 4.2

Schedule 6 – Construction Management Staff (Contract Managers/Technical Staff)			
A. Key Personnel / Professionals			
	Name	Position	Task
Managerial	1.		
	2.		
	3.		
Technical	1.		
	2.		
	3.		
B. Support Staff			
	Name	Position	Task
	1.		
	2.		
	3.		
	4.		
	5.		

SCHEDULE FOR DAY WORKS**SCHEDULE A- LABOUR**

Any labour engaged on Day work shall be paid at the rates given below. Contractor's profit and overheads should not be included in the rates.

No.	Category	Gross Daily Wages LKR
1	Skilled labour	
2	Semi-skilled labour	
3	Unskilled labour	
4	Welder	

SECTION - 10

DRAWINGS

LIST OF DRAWINGS

NO.	DRAWING TITLE	DRG. NO.
01	Thickness Measurements of Bottom and Shell of Tank No.30	CPC_TK30_Bottom_T
02	Thickness Measurements of Bottom and Shell of Tank No.38	CPC_TK38_Bottom_T
03	Thickness Measurements of Bottom and Shell of Tank No.39	CPC_TK39_Bottom_T
04	Drip Gutter	CPC_Tk30_38_39_005
05	Heating Coil	CPC_TTF_HC_001
06	Fire Hydrant Pump House	CPC_TTF_FHPH_001

SECTION - 11
STANDARD FORMS (BID)

FORM OF BID SECURITY

[This Guarantee form shall be filled in accordance with the instructions indicated in brackets]
 _____ *[insert issuing agency's name, and address of issuing branch or office]*

Beneficiary: _____ *[Insert (by PE) name and address of CPC/ Purchaser]*

Date: _____ *[insert (by issuing agency) date]*

BID GUARANTEE No.: _____ *[insert (by issuing agency) number]*

We have been informed that _____ *[insert (by issuing agency) name of the Bidder]* (hereinafter called "the Bidder") has submitted to you its bid dated _____ *[insert (by issuing agency) date]* (hereinafter called "the Bid") for the _____ of *[insert name of Contract]* under Invitation for Bids No. _____ *[insert IFB number]* ("the IFB").

Furthermore, we understand that, according to your conditions, Bids must be supported by a Bid Guarantee.

At the request of the Bidder, we _____ *[insert name of issuing agency]* hereby irrevocably undertake to pay you any sum or sums not exceeding in total an amount of _____ *[insert amount in figures]* _____ *[insert amount in words]* upon receipt by us of your first demand in writing accompanied by a written statement stating that the Bidder is in breach of its obligation(s) under the bid conditions, because the Bidder:

- (a) has withdrawn its Bid during the period of bid validity specified; or
- (b) does not accept the correction of errors in accordance with the Instructions to Bidders (hereinafter "the ITB"); or
- (c) having been notified of the acceptance of its Bid by the Employer during the period of bid validity, (i) fails or refuses to execute the Contract Form, if required, or (ii) fails or refuses to furnish the Performance Security, in accordance with the ITB.

This Guarantee shall expire: (a) if the Bidder is the successful bidder, upon our receipt of copies of the Contract signed by the Bidder and of the Performance Security issued to you by the Bidder; or (b) if the Bidder is not the successful bidder, upon the earlier of the successful bidder furnishing the performance security, otherwise it will remain in force up to _____ *(insert date)*

Consequently, any demand for payment under this Guarantee must be received by us at the office on or before that date.

[Signature(s) of authorized representative(s)]

CHECK LIST FOR BIDDERS

CHECK LIST FOR BIDDERS

Bidders are advised to fill the following table.

ITEM	ITB Clause	YES (tick)	REFERENCE
Form of Bid			
Addressed to the Employer ?	20		
Completed?	20		
Signed?	20		
Bid Security			
Address to the Employer ?	17		
Format as required?	17		
Issuing Agency as specified?	17		
Amount as requested?	17		
Validity 28 days beyond the validity of Bid?	17		
Qualification Information			
All relevant information completed?	4		
Signed?	4		
Addendum			
Contents of the addendum (if any) taken in to account?	11		
Bid package			
All the documents given in ITB Clause 13 enclosed in the original and copy?	13		
ITB Clause 21 followed before sealing the Bid package?	21		